

Series MX

lockable isolation 3/2-way valves

MX2 ports: G3/8, G1/2, G3/4 - MX3 ports: G3/4, G1

Modular

Manual, electro-pneumatic, servo-pilot and pneumatic control

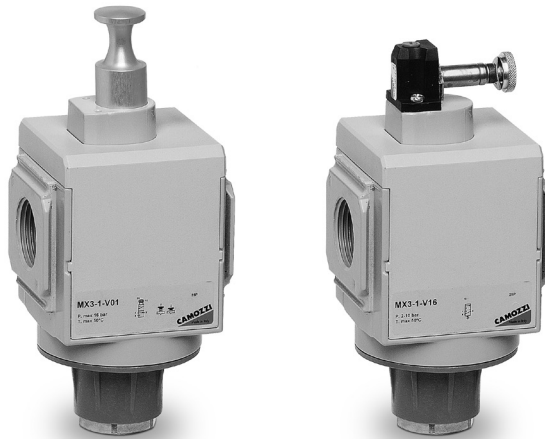

- » Standard tamperproof lock-out (manual valve)
- » One/more locks for the lock-out feature (manual valve)
- » Actuation at 24 V, 110 V or 230 V
- » Exhaust in atmosphere
- » Silencers available on request

The Series MX has been realized to offer a multi-sector solution that guarantees saving in terms of installation time, space and costs. A special configurator, available on Camozzi website at <http://catalogue.camozzi.com> (sec. Configurators), allows the customer to choose the most suitable solution for his application, selecting single components or by configuring assembled FRLs.

Manual isolation valves are ideal to allow an easy access to the FRL group. The system is depressurized with the de-activation of the valve.

Electropneumatic isolation valves: ideal where manual access is difficult, they allow a maximum positioning flexibility and are designed to pressurize or depressurize pneumatic systems. The built-in manual override guarantees security in case of an emergency.

GENERAL DATA

Construction	modular, compact, spool-type
Materials	see TABLE OF MATERIALS (pag. 3/1.35.02)
Ports	MX2: G3/8 - G1/2 - G3/4 MX3: G3/4 - G1
Mounting	in-line wall-mounting (by means of clamps)
Operating temperature	-5°C + 50°C up to 16 bar (with the dew point of the fluid lower than 2°C at the min. working temperature) -5°C + 60°C up to 10 bar (with the dew point of the fluid lower than 2°C at the min. working temperature)
Operating pressure	Manual valve: -0,8 bar + 10 bar Electro-pneumatic valve: 2 bar + 10 bar Servopilot or pneumatic valve: -0,8 bar + 10 bar (with pilot 2 + 10 bar)
Nominal flow	see FLOW DIAGRAMS (pag. 3/1.35.03 e 3/1.35.04)
Nominal exhaust flow at 6 bar with $\Delta p = 1$ bar	MX2: 6000 NI/min MX3: 9200 NI/min
Fluid	compressed air

CODING EXAMPLE

MX	2	-	3/8	-	V	01	-	LH
-----------	----------	----------	------------	----------	----------	-----------	----------	-----------

MX	SERIES
2	SIZE: 2 = G3/8 - G1/2 - G3/4 3 = G3/4 - G1
3/8	PORT: 3/8 = G3/8 1/2 = G1/2 3/4 = G3/4 1 = G1
V	3/2-WAY VALVE
01	DESIGN TYPE: 01 = lockable manual control 16 = electro-pneumatic control 17 = servo-pilot control 36 = pneumatic control
LH	FLOW DIRECTION: = from left to right (standard) LH = from right to left

3

TREATMENT

For the assembly of a single component with fixing flanges or wall-mounting, see the section "FRL Series MX Assembled" (pag. 3/1.50.01)

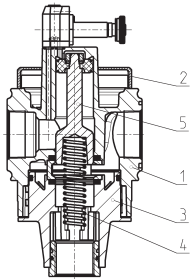
Lockable isolation 3/2-way valves Series MX - materials

PARTS	MATERIALS
1 = Body	Aluminium
2 = Covering	Polyacetal
3 = Valve holder plug	Polyacetal
4 = Lower spring	Zinc-plated steel
5 = Spool	Stainless steel (MX...V16 - V17 - V36) Aluminium (MX...V01)
Seals	NBR

NOMINAL FLOW DIAGRAM for valves Mod. MX...V01

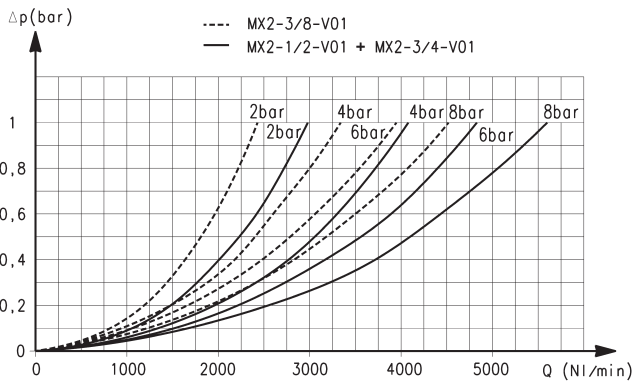

Diagram for lockable manual control valves MX2

Δp = Pressure drop
Q = Flow

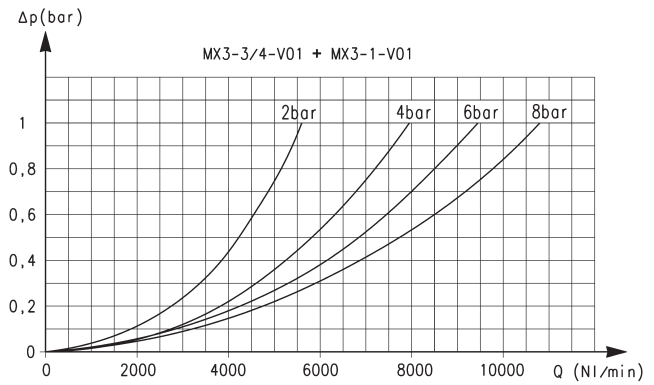
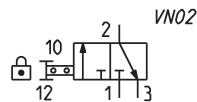
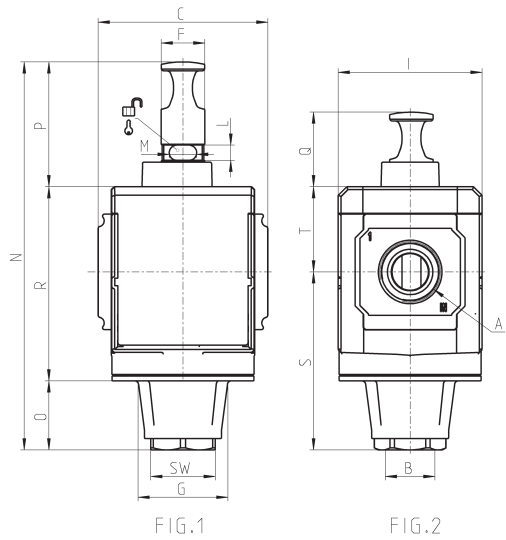

Diagram for lockable manual control valves MX3

Δp = Pressure drop
Q = Flow

Lockable manual valves Series MX - dimensions

Fig. 1 = closed valve
Fig. 2 = open valve



Mod.	A	B	C	F	G	I	L	M	N	O	P	Q	R	S	SW	T	Weight (Kg)
MX2-3/8-V01	G3/8	G 1/2	70	18	34,5	68	9	8	152	13	51	31	88	63,5	27	37,5	0.5
MX2-1/2-V01	G 1/2	G 1/2	70	18	34,5	68	9	8	152	13	51	31	88	63,5	27	37,5	0.5
MX2-3/4-V01	G3/4	G 1/2	70	18	34,5	68	9	8	152	13	51	31	88	63,5	27	37,5	0.5
MX3-3/4-V01	G3/4	G3/4	89,5	23	48	76	8	14,5	205,5	37	66,5	40	102	94,5	34	44,5	0.9
MX3-1-V01	G1	G3/4	89,5	23	48	76	8	14,5	205,5	37	66,5	40	102	94,5	34	44,5	0.9

NOMINAL FLOW DIAGRAM for valves Mod. MX...V16 and MX...V36

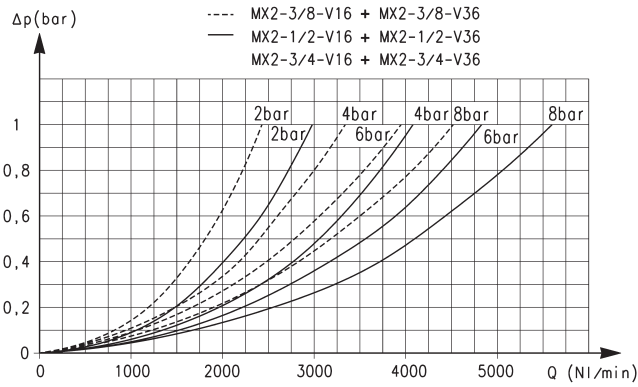

Diagram for electro-pneumatic or pneumatic control valves MX2

Δp = Pressure drop
Q = Flow

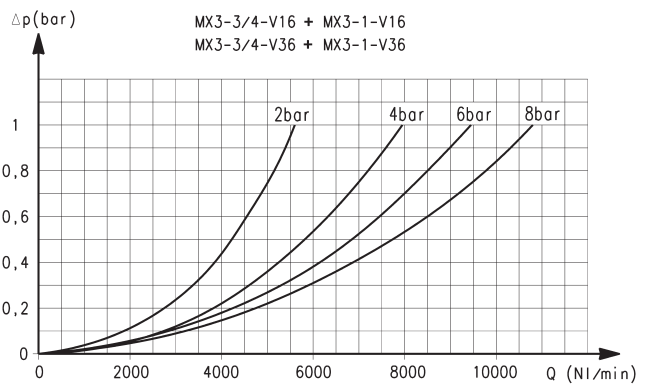

Diagram for electro-pneumatic or pneumatic control valves MX3

Δp = Pressure drop
Q = Flow

3/2-way isolation valves Series MX - dimensions

Electro-pneumatic or pneumatic valves



EV10 = solenoid valve, 3/2 NC, monostable, with bistable manual override

VP01 = pneumatically operated valve, 3/2, monostable, mechanical spring

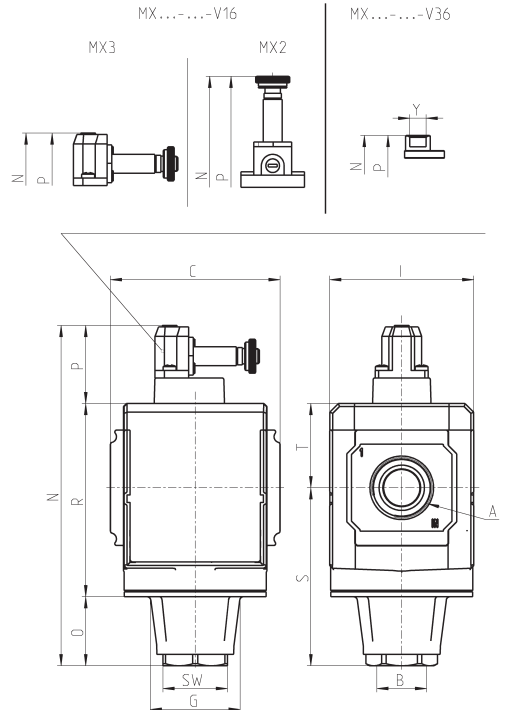
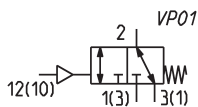
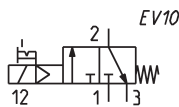

Mod.	A	B	C	G	I	N	O	P	R	S	SW	T	Y	Weight (Kg)	Symbol
MX2-3/8-V16	G3/8	G1/2	70	34,5	68	171	13	70	88	63,5	34	37,5	-	0.5	EV10
MX2-1/2-V16	G1/2	G1/2	70	34,5	68	171	13	70	88	63,5	34	37,5	-	0.5	EV10
MX2-3/4-V16	G3/4	G1/2	70	34,5	68	171	13	70	88	63,5	34	37,5	-	0.5	EV10
MX2-3/8-V36	G3/8	G1/2	70	34,5	68	122	13	21	88	63,5	34	37,5	G1/8	0.5	VP01
MX2-1/2-V36	G1/2	G1/2	70	34,5	68	122	13	21	88	63,5	34	37,5	G1/8	0.5	VP01
MX2-3/4-V36	G3/4	G1/2	70	34,5	68	122	13	21	88	63,5	34	37,5	G1/8	0.5	VP01
MX3-3/4-V16	G3/4	G3/4	89,5	48	76	180,5	37	41,5	102	94,5	34	44,5	-	0.9	EV10
MX3-1-V16	G1	G3/4	89,5	48	76	180,5	37	41,5	102	94,5	34	44,5	-	0.9	EV10
MX3-3/4-V36	G3/4	G3/4	89,5	48	76	164	37	25,5	102	94,5	34	44,5	G1/8	0.9	VP01
MX3-1-V36	G1	G3/4	89,5	48	76	164	37	25,5	102	94,5	34	44,5	G1/8	0.9	VP01

FLOW DIAGRAM for valves Mod. MX...V17

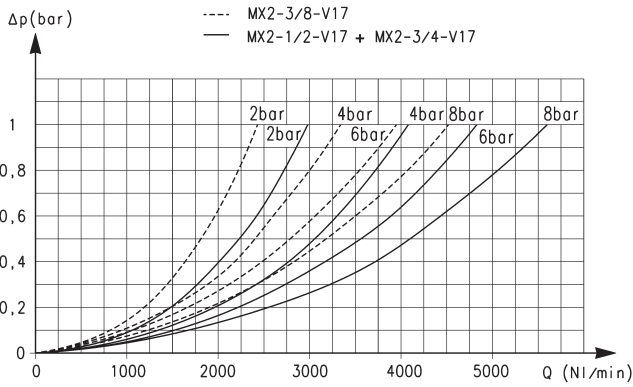

Diagram for servo-pilot control valves MX2

Δp = Pressure drop
Q = Flow

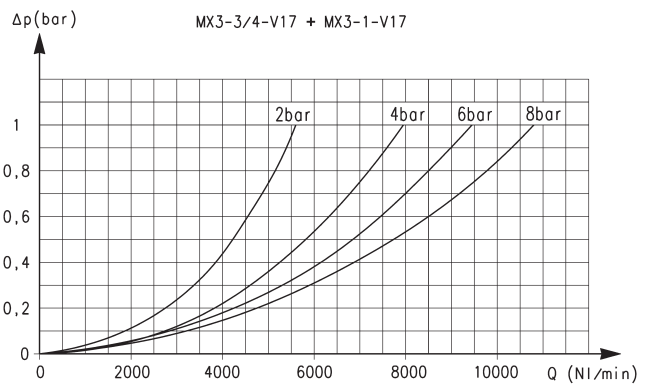

Diagram for servo-pilot control valves MX3

Δp = Pressure drop
Q = Flow

3/2-way isolation valves Series MX - dimensions

Servo-pilot valves



EV11 = solenoid valve, 3/2, monostable, solenoid pilot with separate air supply and bistable manual override

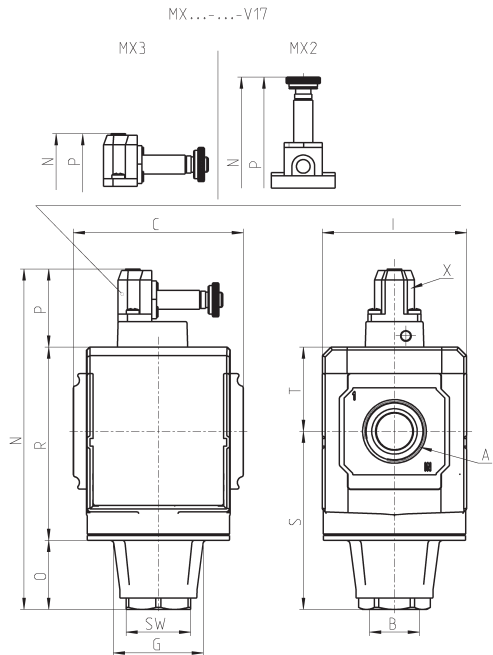
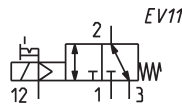

Mod.	A	B	C	G	I	N	O	P	R	S	SW	T	X	Weight (Kg)
MX2-3/8-V17	G3/8	G1/2	70	34,5	68	171	13	70	88	63,5	34	37,5	M5	0.5
MX2-1/2-V17	G1/2	G1/2	70	34,5	68	171	13	70	88	63,5	34	37,5	M5	0.5
MX2-3/4-V17	G3/4	G1/2	70	34,5	68	171	13	70	88	63,5	34	37,5	M5	0.5
MX3-3/4-V17	G3/4	G3/4	89,5	48	76	180,5	37	41,5	102	94,5	34	44,5	M5	0.9
MX3-1-V17	G1	G3/4	89,5	48	76	180,5	37	41,5	102	94,5	34	44,5	M5	0.9